

**BOSS**<sup>TM</sup>



**P1000, P1200,  
P1500 PODIUMS  
AND ANTI-SURF**

**Mobile One Person  
Work Stations**

**User Guide**



# Safety First

## Introduction

---

**IMPORTANT: Never** use the work station until you have fully read and understood this user guide and the work station has been properly set up using the information it contains.

### Safety Checklist

- Is the work station in good condition (see Equipment Care & Inspection sections).
- The total load (1 person plus tools & materials) should not be more than 150kg.
- The castors are pointing outwards and the wheel brakes are locked.
- The access ladder is located correctly.
- The work station is on flat, level, dry and firm ground.
- The work station is correctly positioned to avoid over reaching.
- The platform is at the correct height.
- The safety gate is shut and locked once you are on the platform.





# Safety First

## Equipment care

---

- Every time, before you use the work station, carry out the 6-point inspection detailed in the following section (on page 3).
- Never use the work station if any part is damaged or shows signs of excessive wear.
- Only use this piece of equipment for its intended purpose, as a work station.
- Store the work station somewhere clean, dry and safe. The work station may be stored in the raised or lowered position.
- Keep the work station clean, especially the plywood platform and the rungs of the ladder section. This is easier if you clean it regularly.
- Do not use excessive force to operate the work station mechanisms.



# Safety First

## 6-Point inspection procedure

---

- 1** Check all castors are secure and the fixing bolts are tightened correctly.
- 2** Check all brakes operate and lock the wheel and castor into position.
- 3** Check the tubes and aluminium components of the works station. There should not be any cracks or excessive dents or distortion.
- 4** Check there is free movement of all hinge points of the work station.
- 5** Check the plywood platform. There should not be excessive contamination, cracking, holes or damage, including any missing or damaged rivet fixings.
- 6** Check the following work station locking mechanisms are operating and locking correctly. Ladder claws and locks, gate claw and lock, rear folding frame elbow locking joints and the platform locking tabs.





# Safety First

## Every time you use the work station

---

- 1** **ALWAYS** carry out a Risk Assessment for each job before you start work, to ensure the work station is the appropriate method of access.
- 2** **ALWAYS** check the work station safety check list and follow the instructions in this user guide and the labels on the work station. There is a serious risk of injury if you do not follow all the instructions.
- 3** **ALWAYS** check the work station for damage before you use it, and complete an inspection report if necessary.
- 4** **ALWAYS** make sure that you use the work station on firm and level ground.
- 5** **ALWAYS** try to position the front of the work station towards the work for maximum stability.
- 6** **ALWAYS** wear appropriate protective equipment and work-wear including foot wear with a flat firm sole and a good grip.
- 7** **ALWAYS** take safety measures when working close to doorways, openings and other traffic paths, to prevent accidental collisions but never block an emergency exit, fire-path or other escape route.
- 8** **ALWAYS** secure the work station to prevent unauthorised use.



# Safety First

## When using the work station

---

- 1 NEVER** use this work station until you are sure you are competent in its use and physically able.
- 2 NEVER** overload the work station. The work stations' maximum safe working load is 150kg. This includes any tools and materials.
- 3 NEVER** allow more than one person onto the work station at the same time.
- 4 NEVER** use the work station if any part is damaged or shows signs of excessive wear.
- 5 NEVER** move the work station when a person is standing on it.
- 6 NEVER** over-reach or lean too far over the side of the work station.
- 7 NEVER** carry out jobs that require excessive sideways force. Forces should never exceed 10kg when working with the side of the work station towards the work. Excessive sideways forces may cause the work station to overturn or the wheels to slip.
- 8 NEVER** lean anything against the work station e.g. ladders, steps or materials.
- 9 NEVER** climb up outside of the guardrail.
- 10 NEVER** stand the work station on soft, loose, slippery, sloping or uneven ground.



## Safety First

---

- 11** **NEVER** use the work station outside in adverse weather conditions e.g. strong winds, heavy rain.
- 12** **NEVER** stand on the guardrails, boxes, stepladders or other objects on the platform, to gain additional working height.
- 13** **NEVER** use the work station near power lines or other live electrical equipment.
- 14** **NEVER** suspend the work station from another structure or level.
- 15** **NEVER** Use the work station as a method of gaining access to another structure or level.
- 16** **NEVER** use the work station if you are feeling unwell or you have taken any alcohol, medication or other substance that may affect your ability to work safely.

# Identification

## P1000/P1200/P1500 Podiums

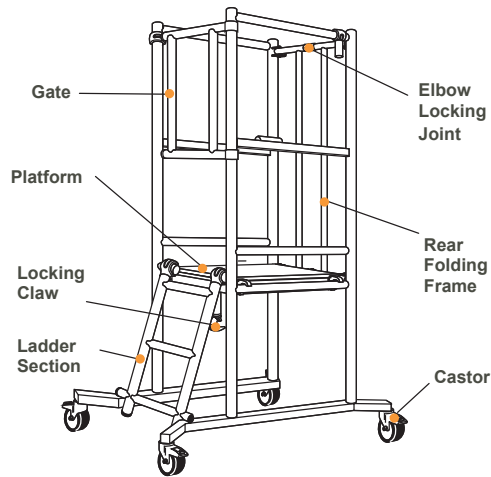

## P1000/P1200/P1500 AS - Podiums

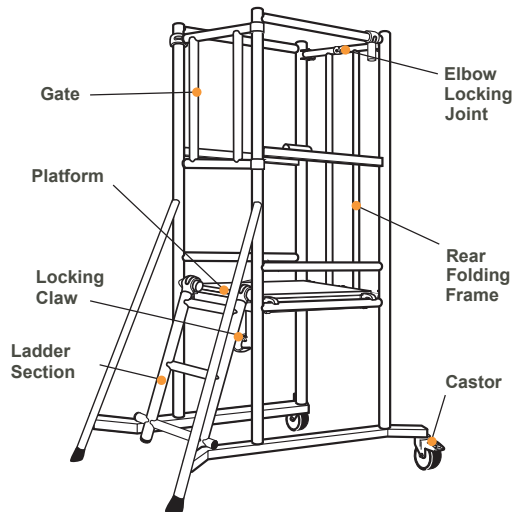

\* Note: Diagrams show P1000 model as example.



# Setting Up

## Moving and positioning the work station

When moving and positioning the work station, ensure that all wheel brakes are unlocked.



The P1000 work station weighs **29kg**, the P1200 weighs **33kg**, the P1500 weighs **39kg** so you may need help if you need to lift it (e.g. in and out of a vehicle)

**Note:** Diagrams show P1000 as example

**IMPORTANT:** Never move and position the work station when anyone is standing on the platform. Remove any tools or materials from the platform before moving the work station. Position the front of the work station towards the work, whenever possible, for maximum stability.

## Opening the work station

- 1 Place the closed unit in the upright position. Unlock all castors.

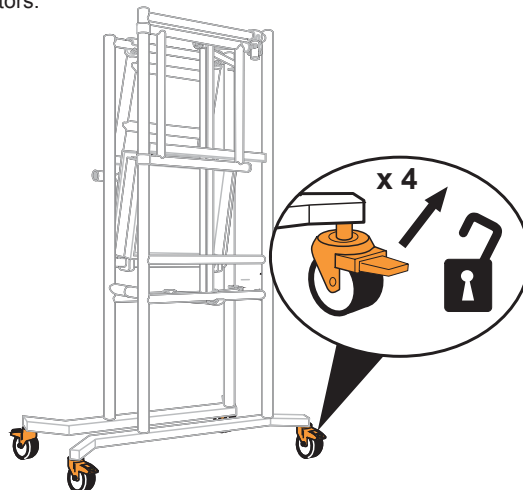

## Setting Up

- 2 Release the locking claw that locks the two side frames together.

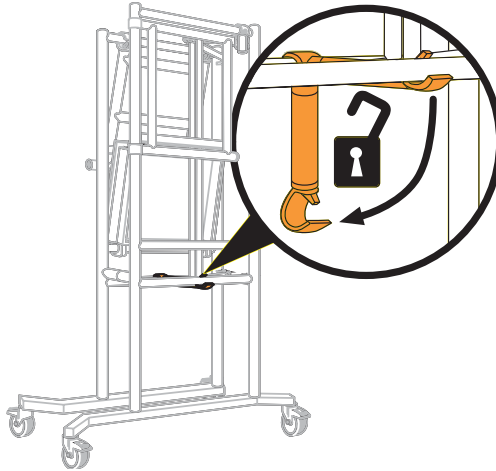

- 3 Open the side frames, which will allow the rear folding guardrail frame to unfold. Ensure the rear folding frame is fully open and both elbow joints are locked.





## Setting Up

- 4** Slide the platform towards the front of the unit (the open end) so that the platform claw is clear of the retaining bar.



- 5** Rotate the platform down and locate the platform claws on the horizontal member of the right hand side frame. Push the platform back towards the back of the unit until it is in contact with the rear folding guardrail frame. Ensure the claws are sitting on the tube and not the plates.

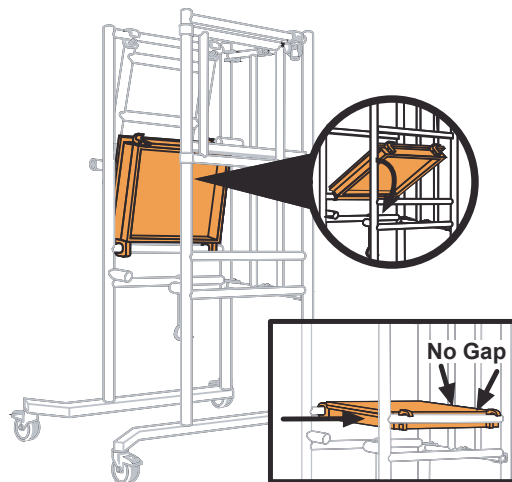

---

# Setting Up

## Positioning the ladder

---

Remove the ladder from the left hand side frame by releasing the ladder locking tab and the two locking claws, situated at the top of the ladder frame.

## Ladder storage position for P1500 & P1200

---

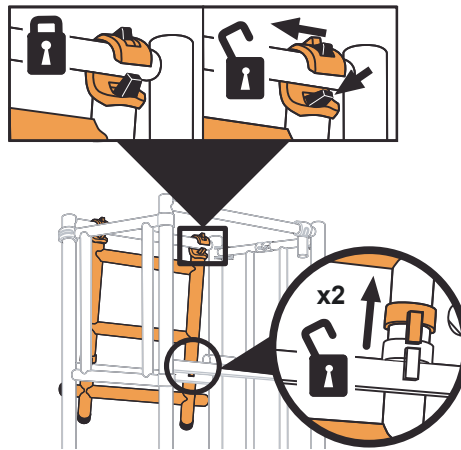

## Ladder storage position for P1500

---

**Note:** P1500 ladder shown as example

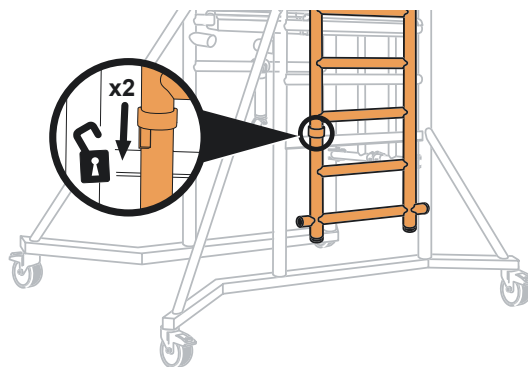

## Setting Up

- 1 Locate the ladder claws over the spigots on the left and right hand side frame. Ensure the claws are locked.

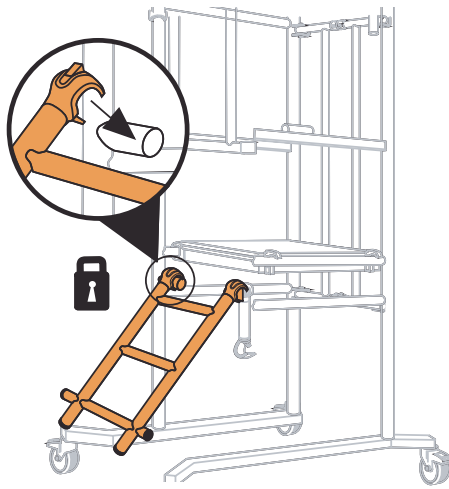

- 2 Rotate the ladder down, using the claws as pivots. Locate the bottom of the ladder over the base frame as shown below.

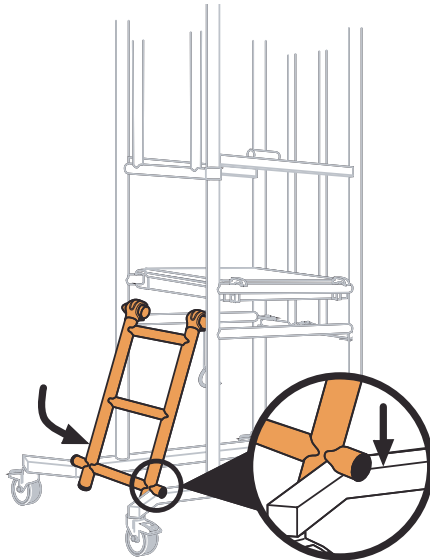

# Setting Up

## Locking the castors

Lock all wheel brakes, with all of the castors pointing outwards, as shown in the diagram.

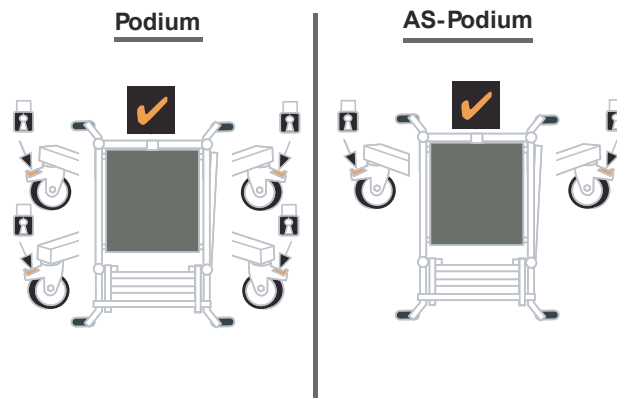

**IMPORTANT:** Never climb on the work station until you have checked the following:

The ladder is secure and positioned correctly.

The platform is secure and positioned correctly.

All castors are positioned correctly.

All castor wheels are locked.



## Setting Up

### Ascending the work station

---

- 1 Ensure the platform is towards the back of the unit and in contact with the rear folding guardrail frame.



- 2 Using the ladder section, climb onto the platform of the work station.





## Setting Up

### Releasing the gate

---

Release the locking claw and rotate the gate to the position shown.

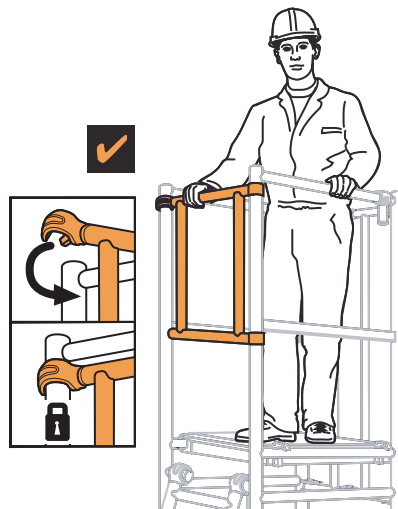

### Closing the gate

---

Close the gate ensuring the locking claw has engaged.

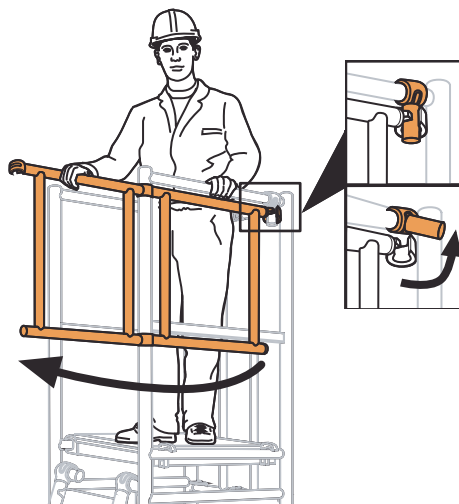





## Setting Up

### Altering the platform height

---

Rotate the platform upwards and unlock both platform retaining plates.

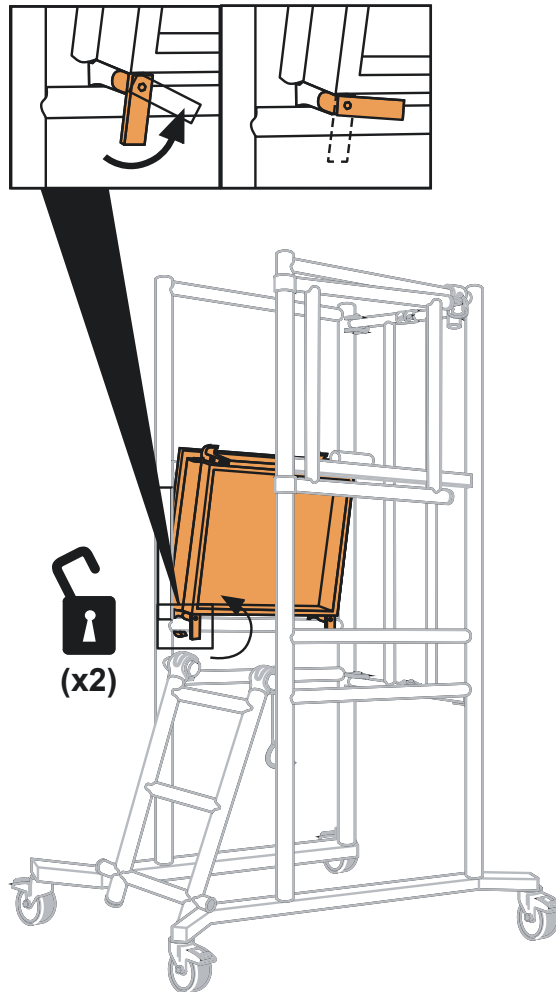



## Setting Up

Position the platform at the lower level

---

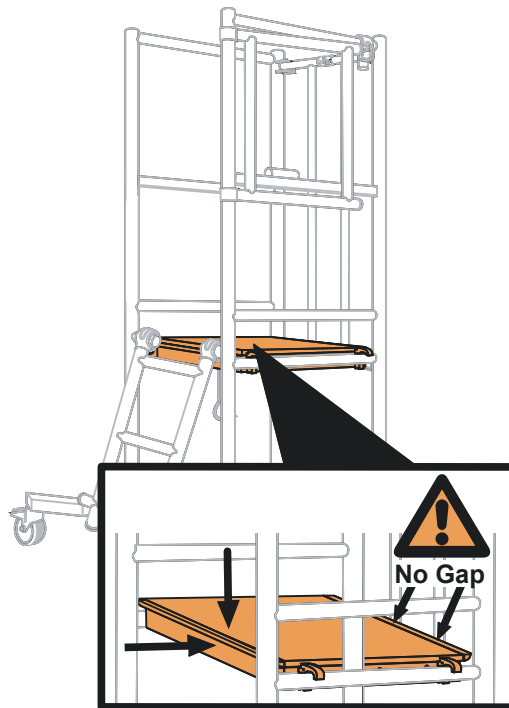

Push the platform towards the back of the unit until it is in contact with the rear folding guardrail frame. Lock the platform retaining plates.

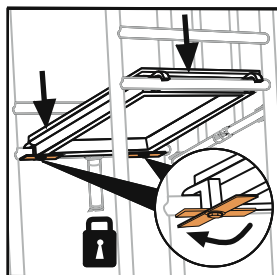





For further information about this product or any other products and services, please contact:

The Causeway, Maldon,  
Essex, CM9 4LJ,  
United Kingdom

☎ +44 (0)1621 745900

☎ +44 (0)1621 859845

✉ [uk.customercare@wernerco.com](mailto:uk.customercare@wernerco.com)

🌐 [bossacesstowers.com](http://bossacesstowers.com)

Part Number: 03356400  
©2016 WernerCo Rev. 09/16

